

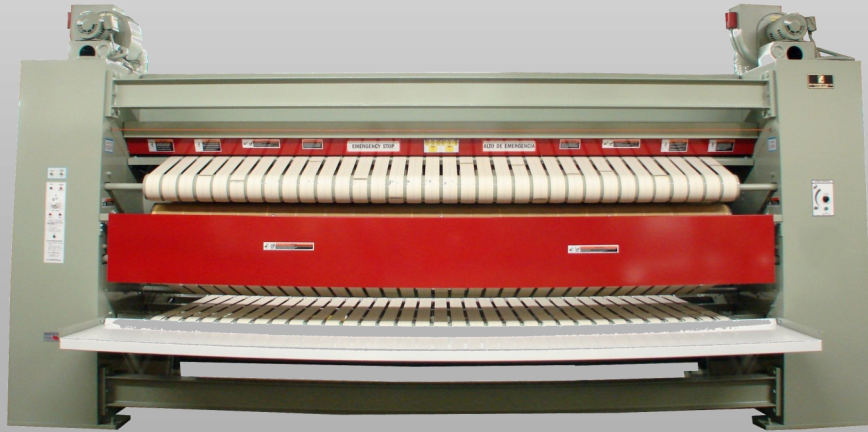

Sharper Finish



**Finish Master 3000  
&  
Finish Master 3600**

**with built-in folder**

*Ask about our optional OSB Smooth Fold System!*

# Finish Master® Ironer with Built-In Primary Folder

## Features

► **Many Sizes.** 120" (3m) ironing width along with optional 132" (3353mm) and 136" (3454mm) widths. 30" (762 mm) or 36" (915 mm) diameter revolving heated cylinder.

► **Simplified.** Made by "The Ironer People"™. This is all we do and we do it well. You cannot find an ironer on the market that is less complicated than the Finish Master®. We work hard to simplify our design so you have less to worry about. The Finish Master® lets you do more with less.

► **Sturdy.** The "mean-green machine". We use thick gauge metal with steel welded construction. This makes the Finish Master® stronger than any other machine in its class, insuring a long life and maximum return on your investment. The entire machine is finished with a high grade "CMV Green" colored machine paint enamel.

► **Built-In Accufold®.** The built-in automatic primary folder increases production and reduces labor costs. The Finish Master® is the only machine that can fold round tablecloths. Folded linen can be removed from the front only or front and rear of the ironer.

► **Versatile.** Clearly the most versatile machine in its class. Adding one operator will more than double potential production.

► **Safety.** ETL approved. Safety features include front, rear, and side interlocked guards, 24V controls, full width hand guard, full width on/off switch cable, properly sized exhaust blower to vent moisture and harmful products of combustion, accurate thermostatic heat control with high temperature shutoff, high gas pressure shut-off switch, and numerous warning labels and instructions.

► **Heating.** The Finish Master® can be heated by gas or steam. The gas heated mod-

els are equipped with the full width multi-port H.O.T.™ (Hold On Temperature) induced draft burner that evenly distributes the heat with a total of nine parts. Compare that to others burners using nearly fifty parts or those that heat oil and have two pumps and long piping to heat the ironer.

► **Quality ironing.** The Finish Master® ironer uses Nomex® padding and ribbons with automated pressure regulation to iron, dry, remove wrinkles, and fold.

► **Options.** Available options include inverter drive, chrome plated heated cylinder, and Intelatrol® II Monitoring System.

► **Intelatrol® Monitoring System.** It is standard on all gas and electrically heated models. We all need to be reminded of things from time to time. Have you ever forgotten to lock a door or turn off a light? Well, your laundry operator could forget to turn off the heat to your ironer, wasting energy and creating a hazard. They cannot forget if they have a Finish Master® equipped with the Intelatrol®. The Intelatrol® will shut off the heat after twenty minutes if the Finish Master® is left unattended. A red light will indicate that the Intelatrol® deactivated the heating system, greatly increasing the life of your ironer ribbons and padding.



Finish Master 3000

# Imagine All Of The Possibilities

THE FINISH MASTER® IS THE MOST VERSATILE MACHINE IN ITS CLASS. DAMP LINEN FED INTO THE FINISH MASTER® IS DRIED, IRONED, RETURNED EITHER TO THE FRONT OR REAR, FOLDED OR FLAT, ALL AT THE CONTROL OF THE OPERATOR.

ALL OF THIS IS DONE USING SIMPLE CONTROLS. CMV SHARPER FINISH HAS ELIMINATED THE NEED FOR COMPLICATED SENSORS AND MEASURING EQUIPMENT.

THE FINISH MASTER® DELIVERS FOLDED LINEN THAT IS 18" (457 MM) WIDE. MODELS ARE AVAILABLE THAT WILL IRON, DRY, AND DELIVER TO THE FRONT ONLY OR TO EITHER THE FRONT AND REAR OF THE IRONER. THE FINISH MASTER® CAN EVEN FOLD

## Front Delivery Operation

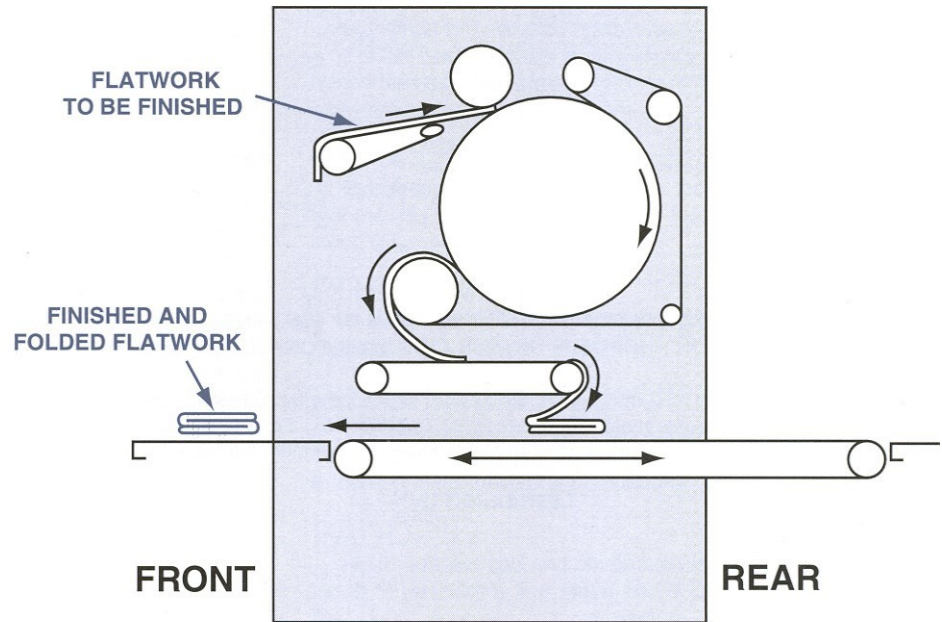

## Rear Delivery Operation

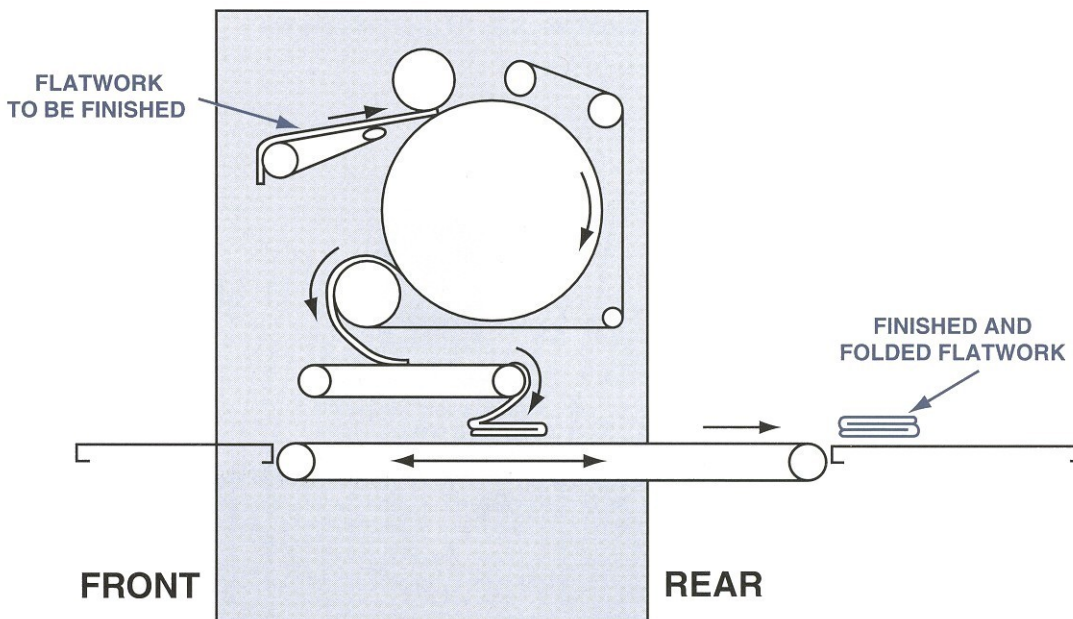

IRONED LINEN DELIVERED TO THE REAR ALLOWS YOUR LAUNDRY TO MORE THAN DOUBLE ITS IRONING PRODUCTION BY ADDING ONLY ONE OPERATOR. THE SINGLE OPERATOR AT THE REAR CAN CROSSFOLD AND STACK THE LINEN BECAUSE THE FOLDER HAS MADE THE JOB EASY FOR ONE PERSON TO HANDLE. THE FOLDER ELIMINATES THE NEED OF TWO OPERATORS AT THE REAR.

## Available Options

### ■ Electrical Voltages

A wide variety of electrical voltages are available including 50 or 60 cycle, single or three phase.

### ■ The OSB Smooth Fold System

The OSB provides a crisp and smooth primary fold. The OSB system keeps the linen tight as the Finish Master makes the primary folds.



Front View of the OSB Smooth Fold System

■ Variety of Ironing widths including standard 120" (3 m); 132" (3.3 m); or 136" (3.4 m)

■ Rigging Eye Bolts

■ Auxiliary Feed Basket

**NOTE:** All of the models covered in this brochure have separate Technical Data and Installation Dimension brochures giving detailed information.

Contact CMV Sharper Finish for this information.

## Other Models Available from CMV Sharper Finish

**We manufacture over 150 different ironer models to meet any of your needs.**

### Single Operator Ironers

The Mini Rite, Finish Rite, and Impress Models are single operator units that return the ironed and dried linen back to the operator. Thousands have been installed in restaurants, clubs, ships and yachts, hotels, assisted living centers, and homes around the world.



Mini Rite

### Mid Sized Ironers

The Models 1200, 1600, and 2000 are available from 85" (2.1m) to 136" (3.4m) ironing surfaces. These models can be heated by gas, steam, or electricity.

### High Capacity Ironers

The Models 2400, 3000, and 3600 are for large laundries ironing hundreds of pounds per hour.

### Ironer, Folder, and Stacker for Tight Space

The IFCS 1600, 2000, 2400, 3000, and 3600 models are ironers with built-in primary and cross folders. A stacker and conveyor are also available.

These combination units save space and labor while offering many of the features once only available on separate ironers and folders



IFCS 2400

► © 2010 by CMV Sharper Finish, Inc. Form CMV906 In view of CMV's policy of providing the best products possible, CMV reserves the right to change specifications and appearance without notice. Contact the sales department for exact specifications, dimensions, and product approvals. CMV manufactures over 100 different ironer models that are sold throughout the world.



### CMV Sharper Finish, Inc.

4500 Augusta Boulevard  
Chicago, Illinois 60651-3399 U.S.A.  
Telephone: 773-276-4800  
Facsimile: 773-276-6878  
Email: sales@cmvsharperfinish.com  
www.ironerpeople.com

Distributed by:

Toll Free U.S.A. and Canada: 800-247-IRON