



Sharper Finish



Finish Master® 3600  
With Built-In Folder

*One of over 100 ironer models we manufacture*

## Features - Finish Master®

\*120" (3m) ironing width. 36" (915mm) diameter revolving heated cylinder, that can process 480 sheets per hour.\* Great for ironing high quality cotton sheets. Also available 132" (3352 mm) and 136" (3455 mm) wide.

\*Made by "The Ironer People"™. This is all we do and we do it well. You cannot find an ironer on the market that is less complicated than the Finish Master®. We work hard to simplify our design so you have less to worry about. The Finish Master® lets you do more with less.

\*The "mean-green machine". We use thick gauge metal with steel welded construction. This makes the Finish Master® stronger than any other machine in its class, insuring a long life and maximum return on your investment.

\*Folded linen can be removed from the front or rear of the ironer.

\*Clearly the most versatile machine in its class. Adding one operator will more than double potential production.

\*The Finish Master® can be heated by gas or steam. The gas heated models are equipped with the full width multi-port H.O.T.™ induced draft burner that evenly distributes the heat with a total of nine parts. Compare that to others burners using nearly fifty parts or those that heat oil and have two pumps and long piping to heat the ironer.

## Dimensions

Dimensions	
A	191" (4851 mm)
B	83" (2108 mm)
C	99" (2476 mm)
D	103 ½" (2629 mm)
E	12" (305 mm)
F	58 ½" (1486 mm)
G	17 ½" (445 mm)
H	22 ½" (572 mm)
I	22" (559 mm)
J	99" (2476 mm)
K	26 ½" (660 mm)

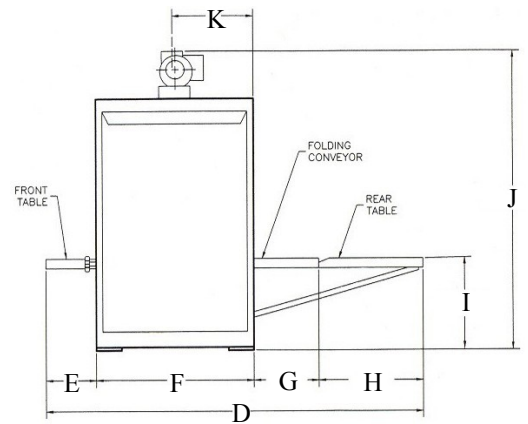
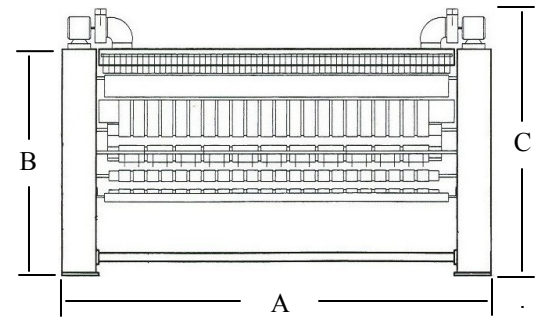

► Each canopy blower discharge is approximately 1050 C.F.M. at 1" S.P. Vent must be independent and not connected with any other vent line. Use 10" diameter vent.

► Allow minimum of 24" (610 mm) clearance at ends of ironer for maintenance access.

► Do not use for construction purposes unless certified correct by CMV Sharper Finish.

► Available for any electrical specification.

\* Rear mode, assumes blended sheets at 25 % moisture retention

► © 2009 by CMV Sharper Finish, Inc. Form CMV933 In view of CMV's policy of providing the best products possible, CMV reserves the right to change specifications and appearance without notice. Contact the sales department for exact specifications, dimensions, and product approvals. CMV manufactures over 100 different ironer models that are sold throughout the world.

## Technical Data

	Model G/AF3600	Model S/AF3600
Finishing Surface Width-Inches (mm)	120 (3048)	120 (3048)
Heated Roll Diameter-Inches (mm)	30 (762)	30 (762)
Finishing Speed-Feet per minute (m/min)	20-100 (6.1-30.5)	25-70 (6.1-30.5)
Electrical Requirements-H.P. (kW)	3+ 2 x 1 (2.24 + 2 x .746)	3+ 2 x 1 (2.24 + 2 x .746)
Maximum Gas Input-B.T.U./hr. (Cal. kg/hr.)	625,000 (183)	-
Steam Consumption-Boiler H.P. (kg/hr.)	-	8 (133)
Net Weight-Pounds (kg)	7950 (3630)	8650 (3950)
Crated Weight-Pounds (kg)	8450 (3859)	9150 (4178)
Crated Size L x W x H-Inches (mm)	176 x 64 x 79 (4470 x 1626 x 2007)	176 x 64 x 79 (4470 x 1626 x 2007)
Crated Volume-Cubic Feet (m³)	515 (14.6)	515 (14.6)



CMV  
**Sharper Finish, Inc.**  
 4500 Augusta Boulevard  
 Chicago, Illinois 60651-3399 U.S.A.  
 Telephone: 773-276-4800  
 Facsimile: 773-276-6878  
 Email: sales@cmvsharperfinish.com

Distributed by:

Toll Free U.S.A. and Canada: 800-247-IRON